

Open Containment Vessel:

Catalog #	Tank Size	Capacity	Length	Width	Height
FC-500	500 gal.	630 gal.	8' 6"	4' 10"	2' 9"
FC-1000	1,000	1,290	12' 0"	6' 6"	2' 10"

- Length, Width, & Height are outside dimensions
- Container has 3" thick walls & floor
- Other sizes can be custom made as needed
- Concrete saddles are available for 4' dia. tanks

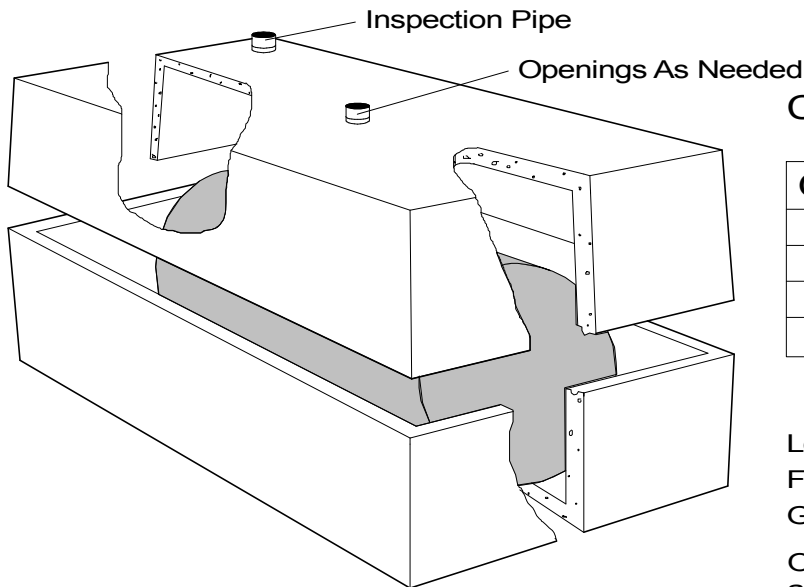
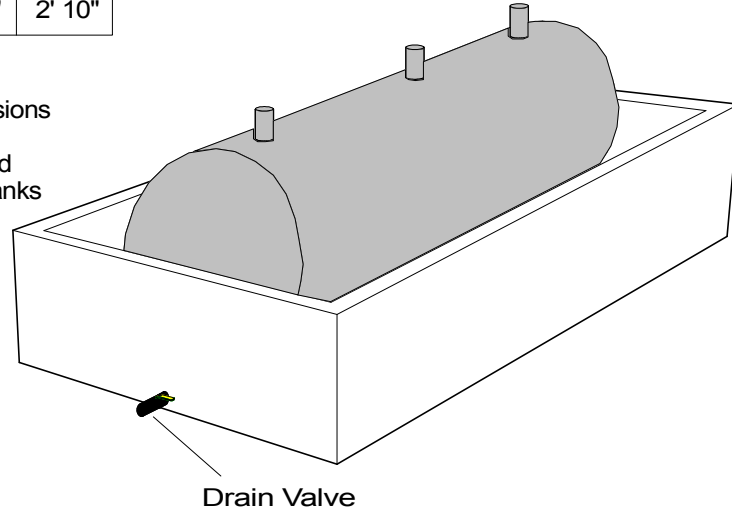

Closed Containment Vessel:

Gallons	L	W	H	Cat.#
630	8' 6"	4' 10"	5' 5"	GT-1000
800	10' 0"	5' 0"	5' 5"	GT-1250
960	10' 6"	5' 8"	5' 5"	GT-1500
1290	12' 0"	6' 6"	5' 7"	GT-2000

Length, width, & height are outside dimensions
For inside dimensions, subtract 6"

Gallon capacity measured to tank seam

Other vents, pumps or pipes can be added as needed.

SPECIFICATIONS	
<p>Concrete Min. Strength: 4,000 psi at 28 days Reinforcement: #3 Rebar, 10ga. Wire Mesh Air Entrainment: 6%</p>	<p>PRECAST FUEL CONTAINMENT 300 TO 1,000 GALLON TANKS</p> <p>Woodard's Concrete Products, Inc. 629 Lybolt Road, Bullville, NY 10915 (845) 361-3471 / Fax 361-1050</p> <p>Page 12F 7/11/2018</p>